

SPEC PACK LAUNDRY COLLECTION

SPEC SHEET



NUGLEAM 35L UTILITY SINK

PRODUCT CODE:

73300

FEATURES:

- / 35L bowl with centre taphole
- / 304 stainless steel bowl with 25mm internal corner radius
- / 90mm stainless steel basket waste
- / Minimalist style with flat edge design

OVERALL DIMENSIONS: 555 L x 455 W x 225mm D

WARRANTY:

25 years - Stainless Steel
1 year parts and labour

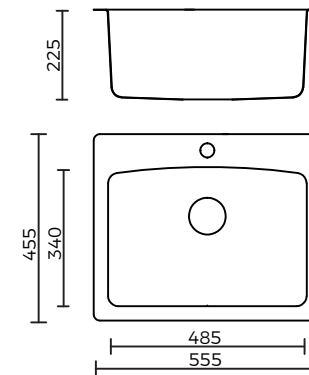

Disclaimer: All measurement are in millimetres and are solely for reference purposes. Colours have been reproduced with as much accuracy as possible. Any changes resulting from technical advance of design or colour may be made without prior notice. Tapware, accessories and appliances are for illustration purposes only. Further information on warranties is available at www.everhard.com.au

SPEC PACK LAUNDRY COLLECTION

PRODUCT DRAWING

