

SPA PUMP COVER

Bath Accessories

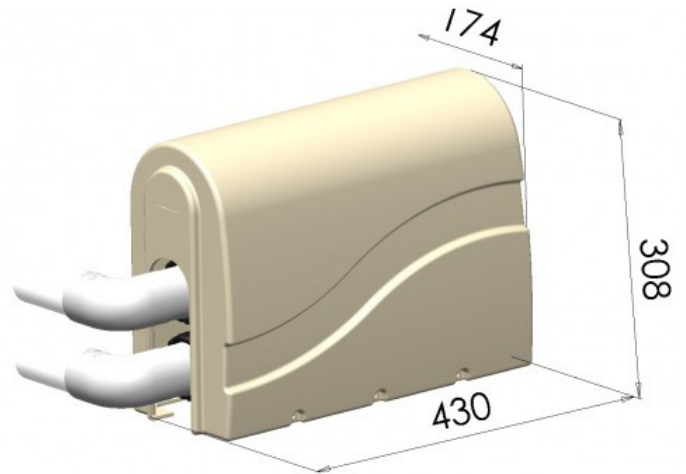
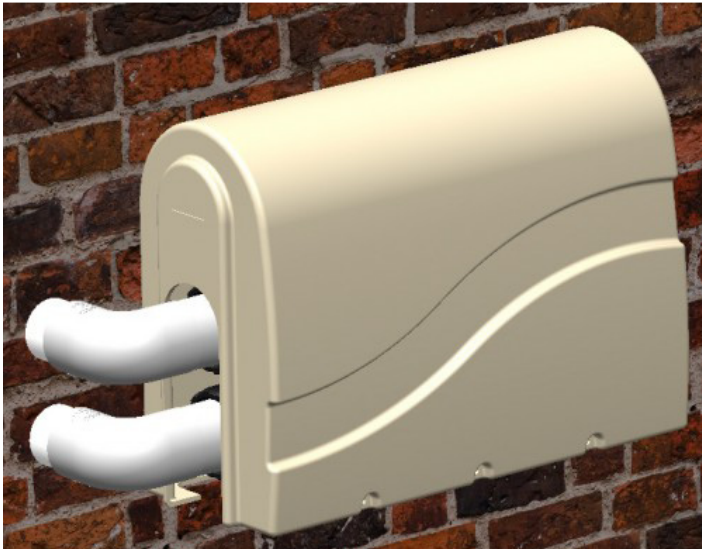

OUTDOOR SPA PUMP COVER

The new Pro-Tec pump cover is complete with wall brackets and mounting base and can be adapted for left hand or right hand mount-standard and TriFlo applications.

The rotor molded cover protects the spa bath pump from all weather conditions and can be easily removed if required.

The Pro-Tec pump cover will further reduce the noise level and is molded in a neutral Merino colour.

MODEL CODE

- EDG119

SIZE (l)x(w)x(h)

- 430 x 174 x 308 (mm)

KEY FEATURES

- Spa Pump cover suitable for outdoor use
- Wall brackets
- Mounting base
- Suitable for left hand or right hand mount
- Merino coloured

MATERIAL

- Low Density Poly Ethylene

WARRANTY

- One year warranty -
Conditions apply please see website for details